

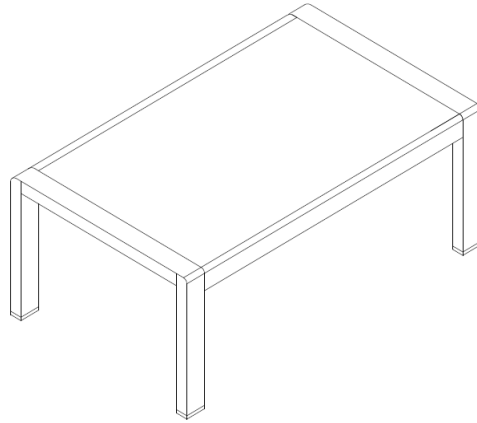



Assembly Instructions

Caution: You must read this before you proceed



Table

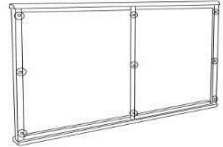

Parts List

Label	Picture	Description	QTY
A		Left Leg	1
B		Right Leg	1
C		Table Top Frame (with Suction Cups)	1
D		Glass Top	1

Hardware

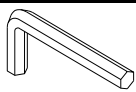
Label	Picture	Description	QTY
①		Bolt(M6*20MM)	5
②		Bolt(M6*25MM)	5
③		Allen Key	1

Assembly Preparation

Before Beginning Assembly:

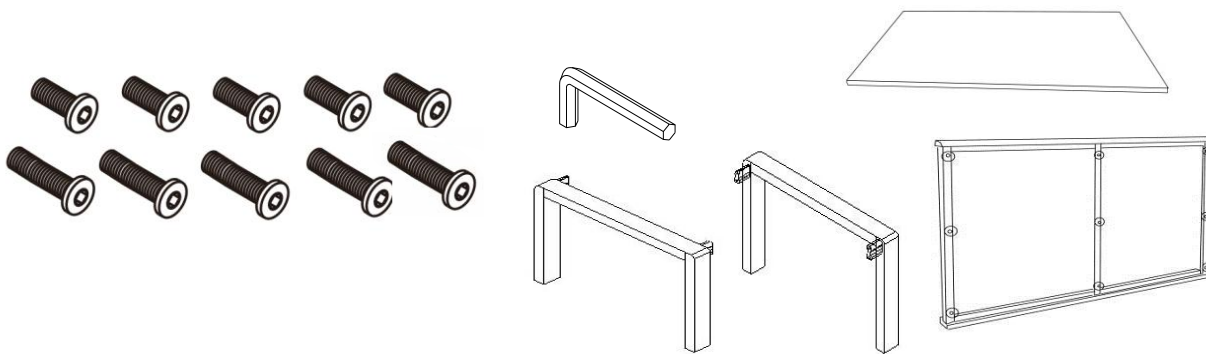

- Read instructions, cover to cover-



- Have 2 adults on hand for assembly-



- Do not assemble on flooring or carpet-



- Assemble on a clean non-marring surface (packing foam)-



- Save all packaging until finished-

Assembly Steps

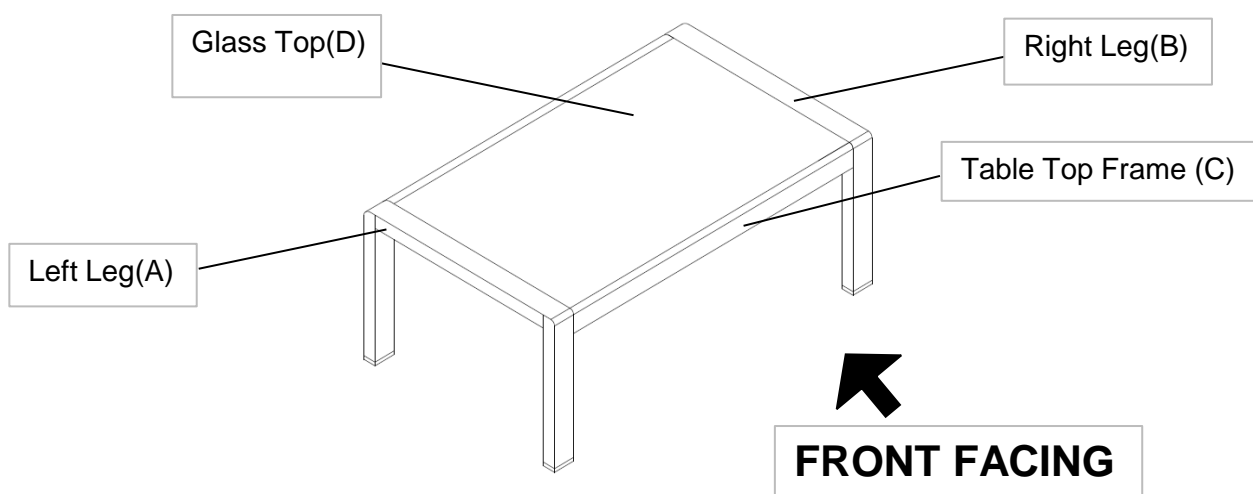

This Table has multiple parts and may require up to some 30 minutes to assemble. To give you an overview of the Table parts, the above picture is to help you put the various parts into perspective. Please read through the instructions below to familiarise yourself with the parts and steps before assembly.

Step 1

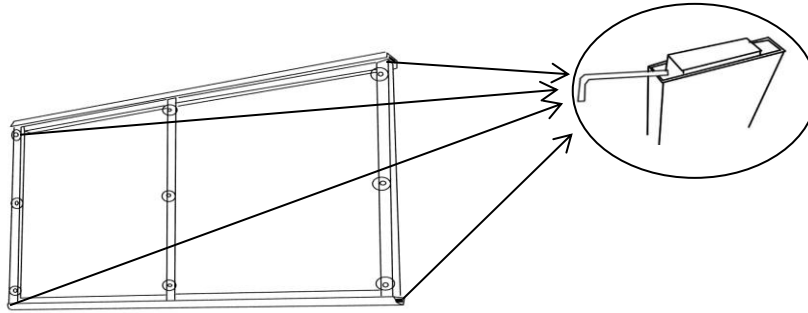

Take out the sliders in the four ends of Table Top Frame(C) using Allen Key(③).

Step 2

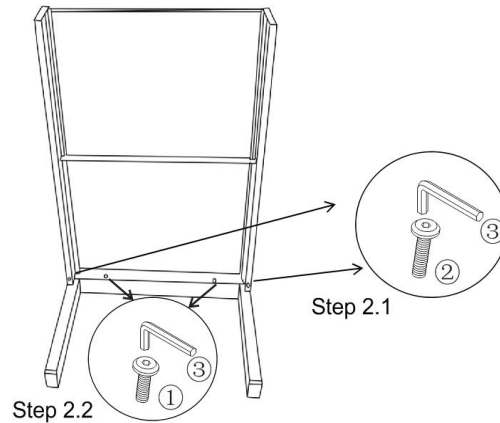

Open the carton and place all the parts on a clean, non-marring surface.

2.1 Attach the Table Top Frame(C) to the Left Leg(A) using Bolt(②) and Allen Key(③) as shown in the picture.

2.2 Attach the Table Top Frame(C) to the Left Leg(A) using Bolt(①) and Allen Key(③) as shown in the picture.

Do not fully tighten the Bolt.

Caution: The Table and its Parts are Heavy. Two adults are required for lifting and moving them.

Step 3

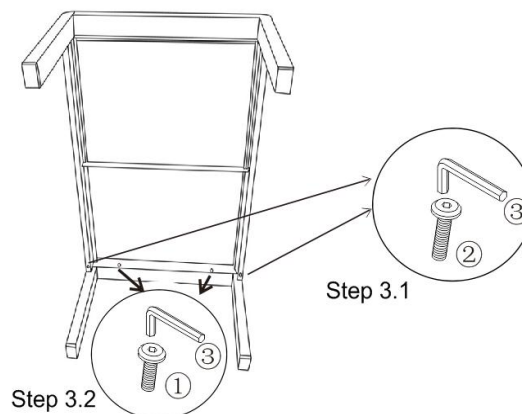

3.1 Attach the Table Top Frame(C) to the Right Leg(B) using Bolt(②) and Allen Key(③) as shown in the picture.

3.2 Attach the Table Top Frame(C) to the Right Leg(B) using Bolt(①) and Allen Key(③) as shown in the picture.

Do not fully tighten the Bolt.

Caution: The Table and its Parts are Heavy. Two adults are required for lifting and moving them.

Step 4

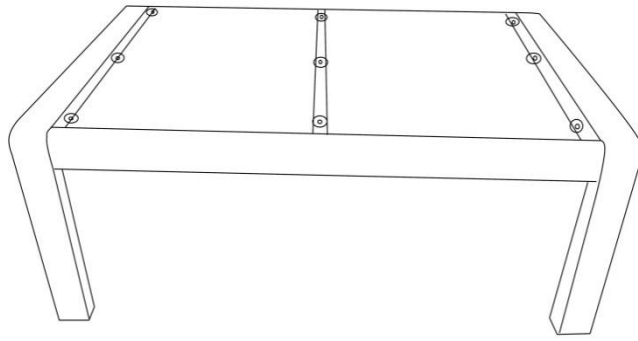

Stand up the table, check stability and then tighten the bolts.

Note DO NOT fully tighten a BOLT in one go and then move on to the next. Rather, In a sequential manner, gradually tighten each Bolt until all bolts are evenly secured. This methodology will ensure maximum evenness once all Bolts are fully tightened.

Step 5

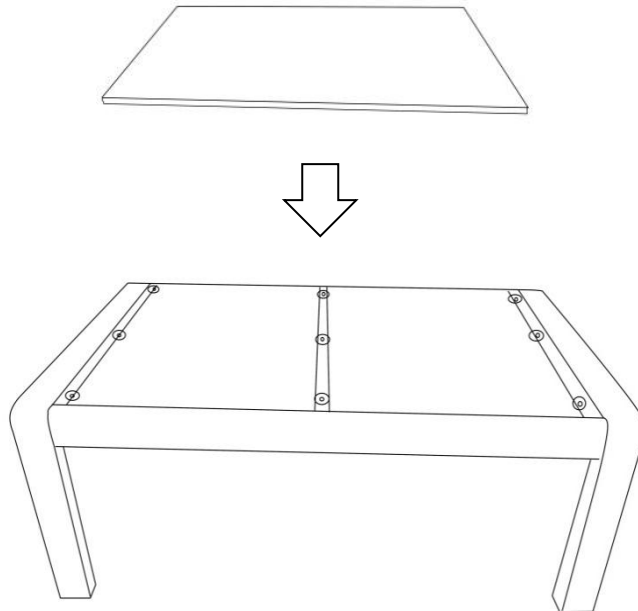

Place the Glass Top(D) on the assembled Table Frame.

Caution: The Table and its Parts are Heavy. Two adults are required for lifting and moving them.

Step 6

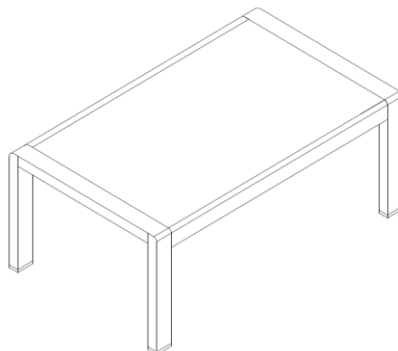

Your Table is ready for use.

